

VENTILATION FITTING SYSTEMS

MADE OF THERMOPLASTICS

for permanent application in exhaust air

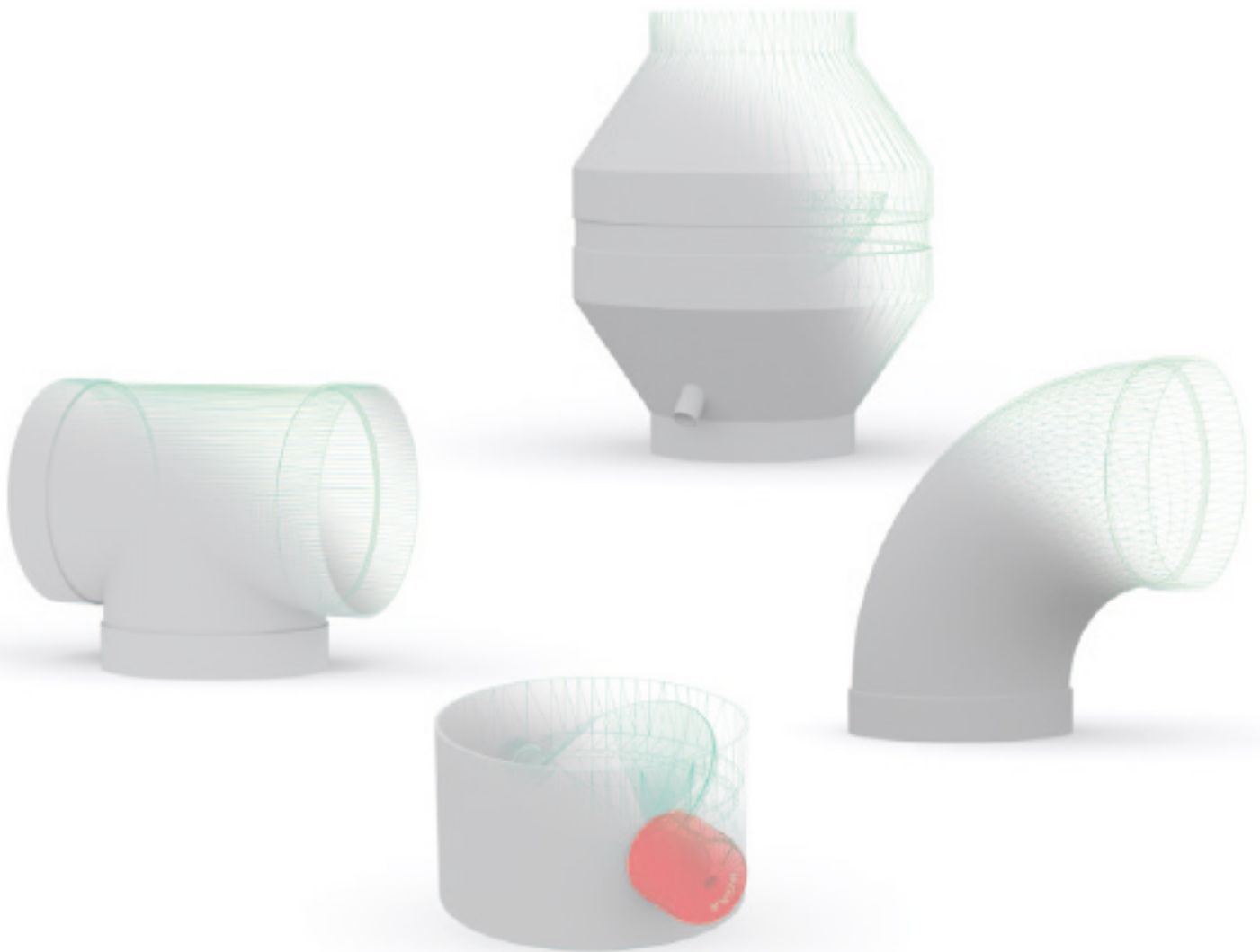

PRE-MADE POLYMER VENTILATION DUCT FITTINGS

ELIMINATE THE NEED FOR CUSTOMISED FABRICATION

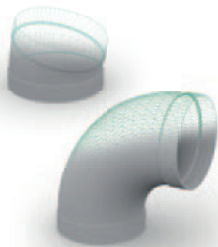

HoKa Bends



*HoKa Branch outlets
(T-Piece) 90°*



*HoKa Branch outlets
(T-Piece) 45°*



HoKa Double sockets



*HoKa Control valves
prepared for motor*



HoKa Flanges



HoKa Flexible connectors

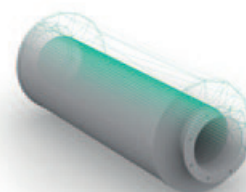

*HoKa Sound attenuators
(reducer)*

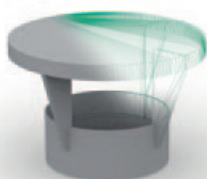

HoKa Outlet cowls

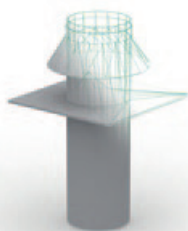

HoKa Roof heads

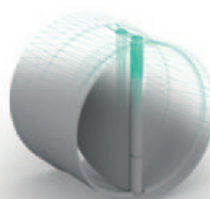

HoKa Back flow dampers

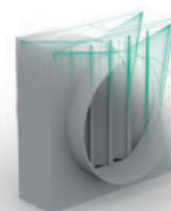

HoKa Back flow damper

HoKa GmbH is a specialist manufacturer of moulded polymer ventilation duct fittings, which has been in operation for more than 25 years.

HoKa fittings are produced in a large array of sizes with dimensions ranging from 50 to 1250 mm diameter. These plastic fittings are available in all commonly required

arrangements such as bends, junctions, joiners and transitions. This vast range virtually eliminates the need for custom fabrication.

HoKa fittings are manufactured using a controlled process that guarantees dimensional accuracy. Each fitting is produced with joining collars on all openings to further simplify the assembly process.

* PVW = Polyvinyl chloride, PP = Polypropylene, PPs = flame resistant Polypropylene, Pe = Polyethylene, PP-el-s = electrically conductive, flame resistant Polypropylene, PVDF = Polyvinylidene fluoride

& FITTINGS RICATION

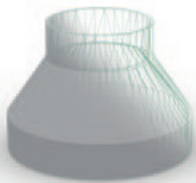

HoKa Reducers



*HoKa Damper valves
with handle*



*HoKa Damper valves
with control knob*

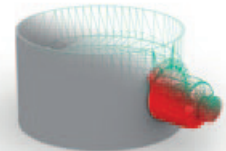

*HoKa Damper valves
adjustable with locking knob*



*HoKa Condensers
deflector housing*



*HoKa Saddles
90° Outlet*

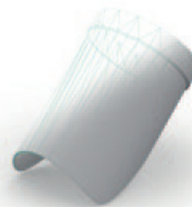

*HoKa Saddles
45° Outlet*

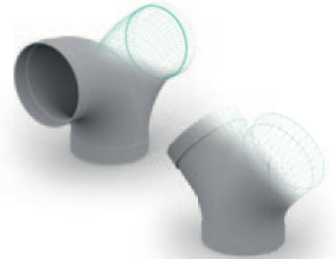

HoKa Breech 90° Outlets

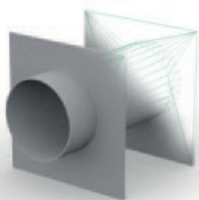

HoKa Through walls

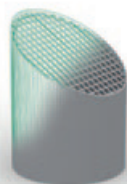

*HoKa Outlet with grilles
30° angled*



HoKa End capes

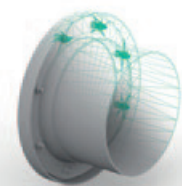

HoKa Cleaning orifices

Other dimensions and types of fittings can also be produced to meet individual requirements.

Produced in * PVC grey & white, PP, PPs, Pe, PP-el-s and PVDF, HoKa plastic fittings are suitable for all exhaust and ventilation systems, including the extraction of corrosive and volatile fumes. PVC duct and fittings can be joined by solvent welding whilst

the joining of other materials (PP, PPs, Pe, PP-el-s & PVDF) is done by a plastic welding process.

Our aim is to ensure continuous availability and short delivery times on all HoKa products. For sure you get free advice and consultation on the selection and use of HoKa duct and fittings.

TECHNICAL SPECIFICATIONS

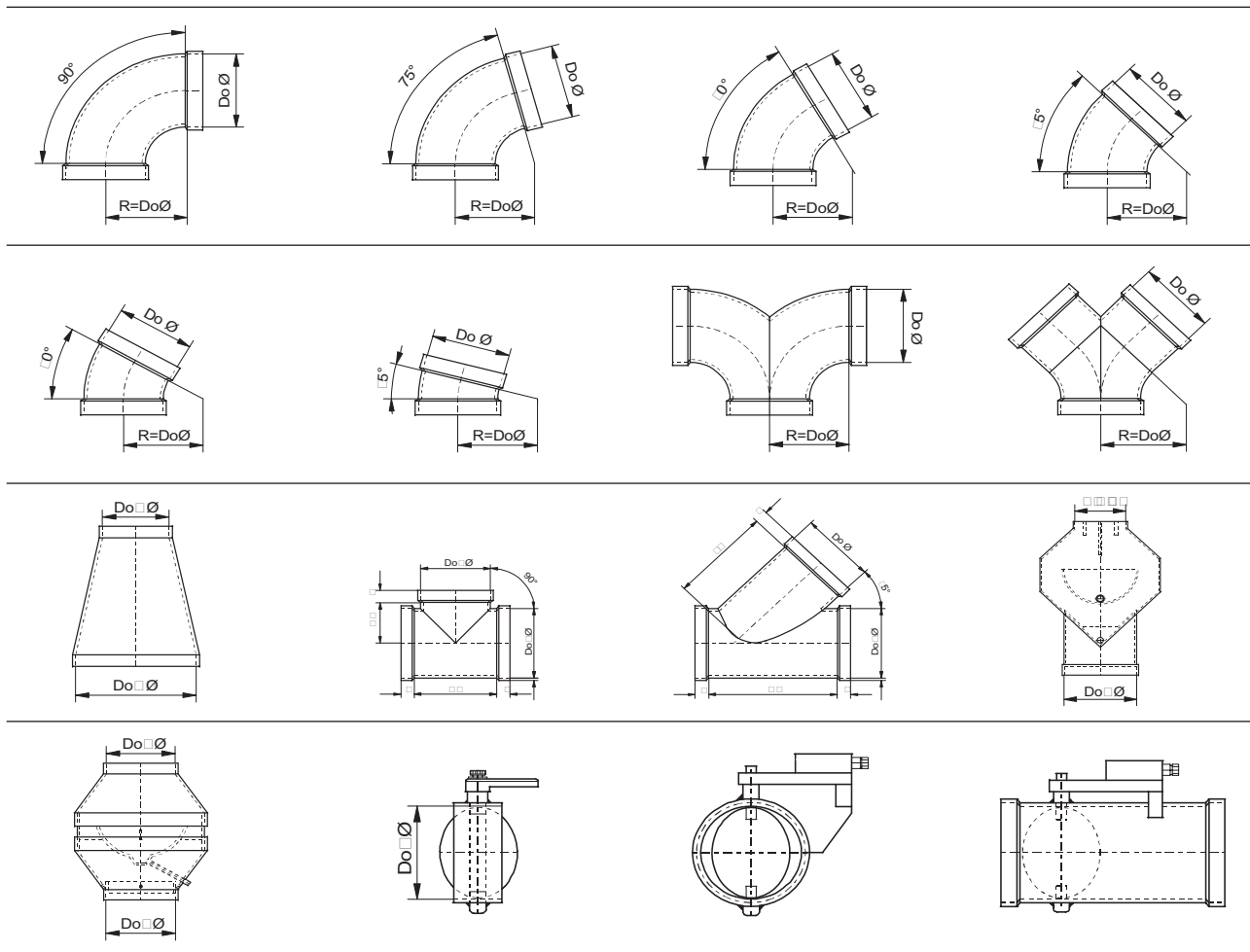

YOUR CONTACT IN AUSTRIA



AURO Austria GmbH

Lichtblaustraße 21
A-1220 Wien

Telefon: +43/1/256 55 55
Telefax: +43/1/256 55 55 55
E-Mail: wien@auro.cc
Web: www.auro.cc

HoKa - Gesellschaft für Lüftungsformteile aus Kunststoff mbH

Reutherstraße 12 . 53773 Hennef
Telefon: +49 (0)2242 / 92 51 0 . Telefax: +49 (0)2242 / 92 51 20
E-Mail: hoka@hoka.de . www.hoka.de

